



iCON

SERIES TANKZ



Please ensure you read and understand the instructions before installation.

INSTALLATION INSTRUCTIONS
(iCON2700; iCON3750; iCON4800; iCON6500)

Important Safety Notice

For personal safety reasons the instructions described in this document must be followed under all circumstances. Warranty rights will not be recognised if installations do not comply with these instructions. These instructions are specifically designed for the iCON Carat rainwater tank (Sizes: 2700L; 3750L; 4800L; 6500L) Please contact your supplier immediately if instructions are incomplete or missing. The tank must be checked for any damage upon receipt and again before placement into the trench, Installation must be carried out by a licenced installer.

BACKFILL MATERIALS

Preferred back fill materials: 7mm quarter minus, washed sand

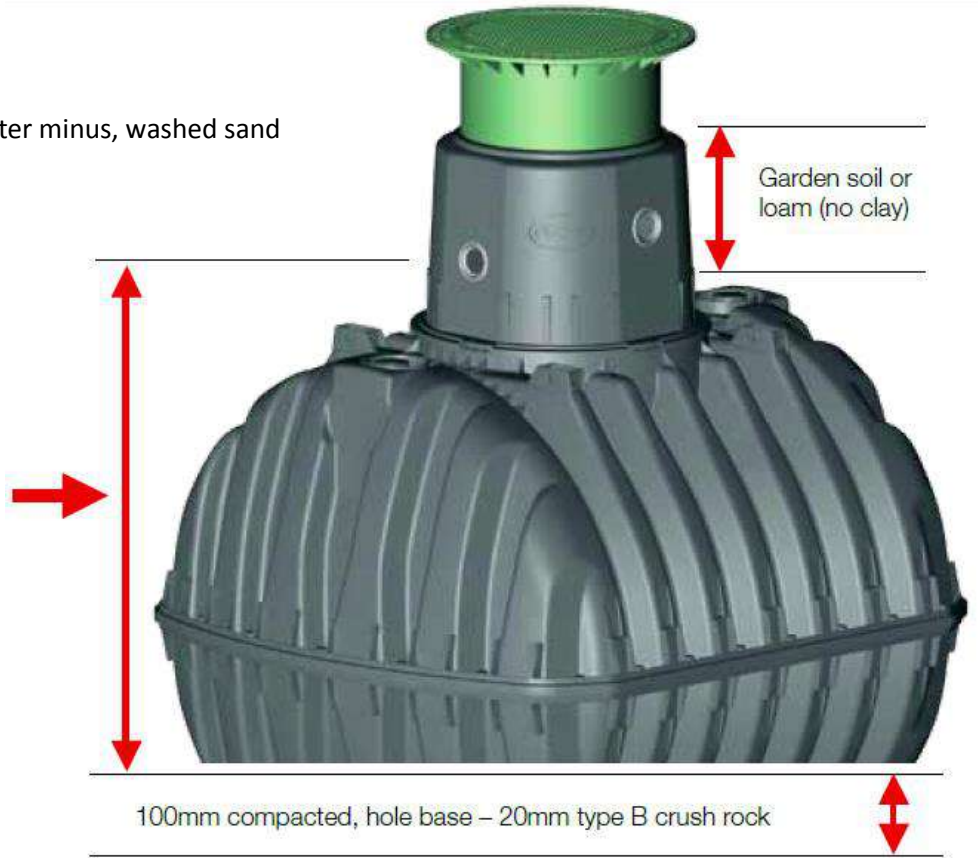

100mm "Compacted" Hole Base 20mm type B Crushed rock (porous)



Wrong backfill – Non porous Materials (DO NOT USE)

Builders sand, Clay, Cement, Types C & D Crushed rock, and any other non porous or water holding soils. Incorrect soils used may affect warranty.



General safety instructions

Safety

As Work, Health and Safety Legislation differs in each state and territory, it is necessary to refer to all relevant Work, Health and Safety legislation, regulations and Australian standards in your state or territory at all times during installation, assembly, servicing and repair of the iCON tank systems.

Current statutory regulations and all relevant Australian standards must be taken into consideration at all times.

The system and any of its individual parts must be installed by a licenced person. Installation by a non-licenced person may void warranty.

The entire system must be shut down before any maintenance can be undertaken. Once maintenance is completed the tank must be properly sealed/locked by means provided with the tank to prevent future unauthorized entry.

We offer a wide range of accessories which all match each other. The use of non-authentic accessories may void the warranty and can indemnify us against any subsequent claims of liability from any resulting damages.

Maintenance

In the even that work needs to be carried out inside the tank, local Work, Health and Safety legislation for work in confined spaces must be followed.

Site

Work, Health and Safety legislation for the local area must be followed for excavation and trenching and use of equipment for the installation of the tank.

Lifting of tanks

Local Work, Health and Safety legislation must be followed when lifting, handling or moving iCON water tanks.

Protection of site

It is the responsibility of the installing contractor and the property owner to ensure that the area where the tank/tanks are installed is protected against damage by third parties during and after the completion of the installation. E.g. keep heavy vehicles out of the construction area.

Future landscaping works

When locating the tank, ensure you take into consideration the location and positioning of future landscaping features such as garden beds, paths, driveways, brick walls etc.

Depth of soil cover over tank

Adjustments of telescopic shaft

Soil depth of telescopic shaft in garden area Note: for standard telescopic shaft & lid, Min 750mm – Max 950mm, maximum load rating of standard lid is 150kg

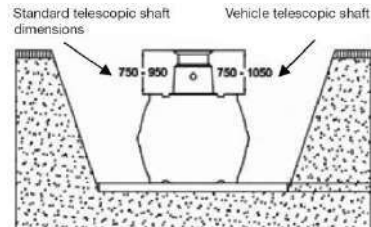

Diagram 2.1

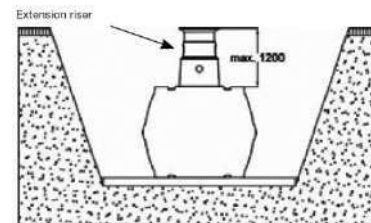

Diagram 2.2

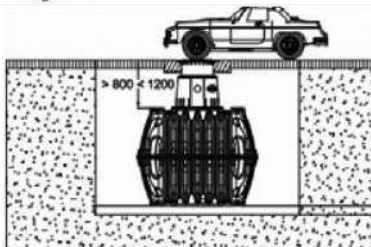

Diagram 2.3

Extension riser

Extension riser and telescopic shaft

Suitable for low water pipes or where existing hole is deeper than the required height for the tank, or where the contractor has already installed the tank and his ground level is higher than the shaft fully extended. This is also suitable in areas susceptible to below freezing temperatures. Note: if groundwater exists. Maximum soil depth of 1000mm

Passenger Vehicles

Soil depth of telescopic shaft and removable cast iron lid (Class B) in areas subject to passenger vehicle traffic (without groundwater). Refer to diagram 6.5

Note: For vehicle telescopic shaft min 800mm – max 1200mm

Max weight over Graf tanks = 3.5 tonnes gross vehicle mass (GVM)

Trucks

Carat tanks must not be installed below areas used by vehicles heavier than passenger cars. For Class D loading, please contact your tank supplier

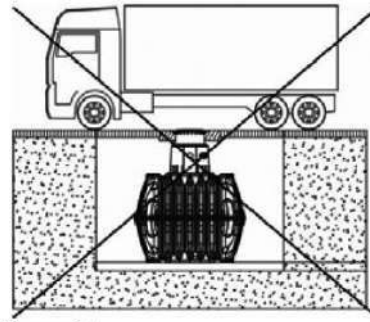

Diagram 2.4

Ground Water

Soil depth of installation in groundwater – the shaded area illustrates the allowable immersion depth for the tank (not under areas subject to vehicle traffic) Groundwater level must not be higher than the midline join of the tank shell. If ground water is higher than the midline join contact your supplier

Refer 5.3.1

Note: Min 800mm – Max 1000mm
(require iCON Maxi Lid)

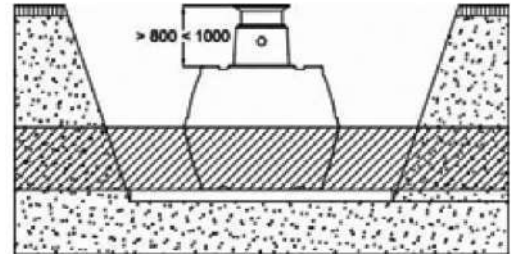
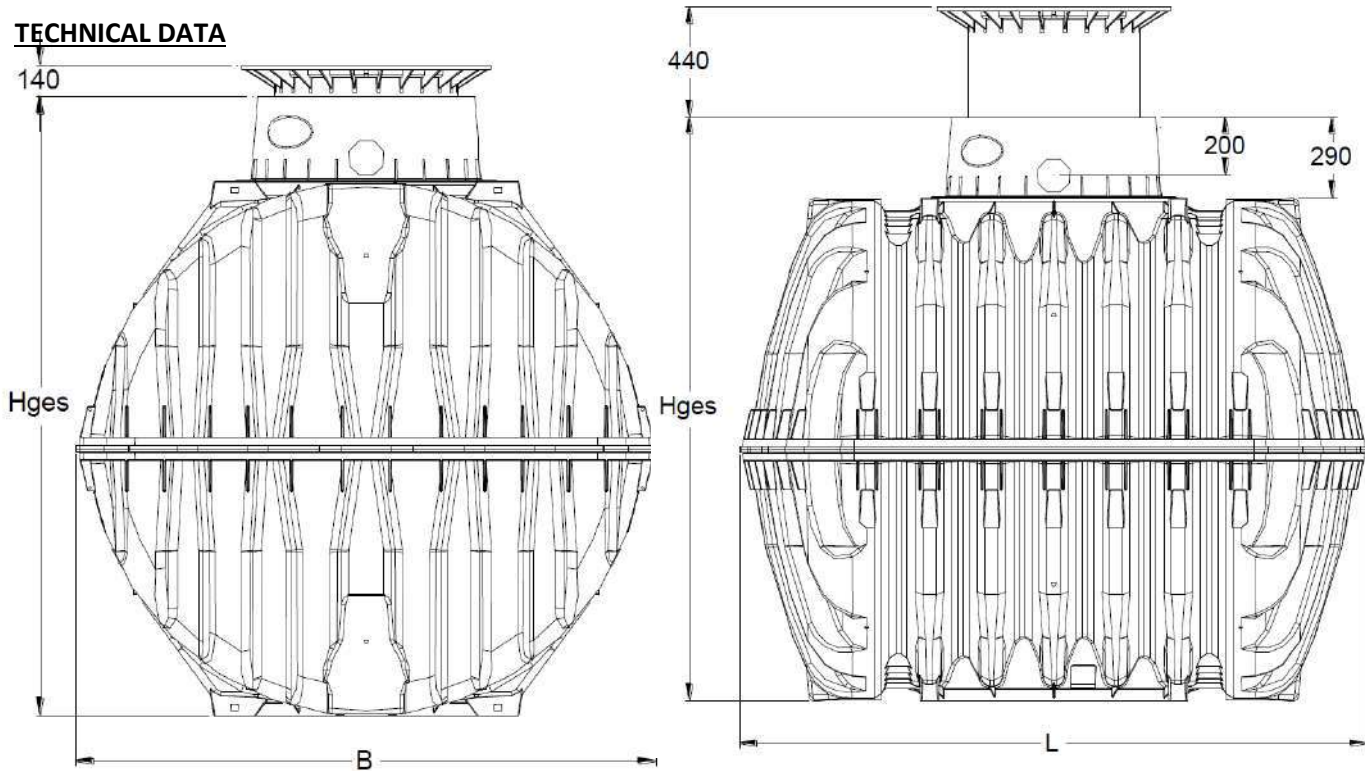

Diagram 2.5

Settling of soil

Settling of soil might occur and consideration needs to be given to allow for such.

TECHNICAL DATA



DIMENSIONS				
TANK	2700 LITRES	3750 LITRES	4800 LITRES	6500 LITRES
WEIGHT	120 kg	150 kg	185 kg	220 kg
L	2080mm	2280mm	2280mm	2390mm
B	1565mm	1755mm	1985mm	2190mm
H	1400mm	1590mm	1820mm	2100mm
Hges (mini dome)	1680mm	1870mm	2100mm	2380mm
MINIMUM HOLE SIZE (L X W X H)	2680mm x 2165mm x 2300mm	2880mm x 2355mm x 2490mm	2880mm x 2585mm x 2720mm	2990mm x 2790mm x 3000mm

Tank Structure

1. Cover

①



2. Telescopic dome shaft
(can be inclined 5°)

②

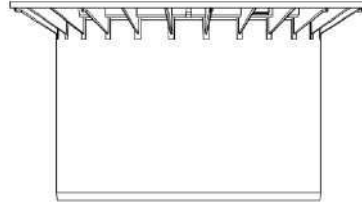

3. Profile seal

③

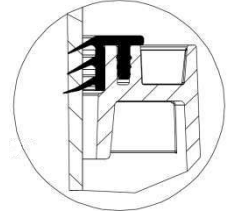

4. Tank dome

④

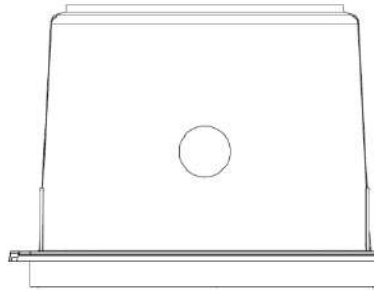

5. Tank – tank dome seal

⑤

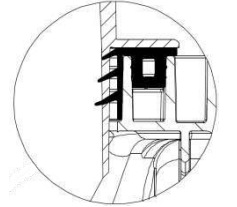

6. iCON underground
tank

⑥

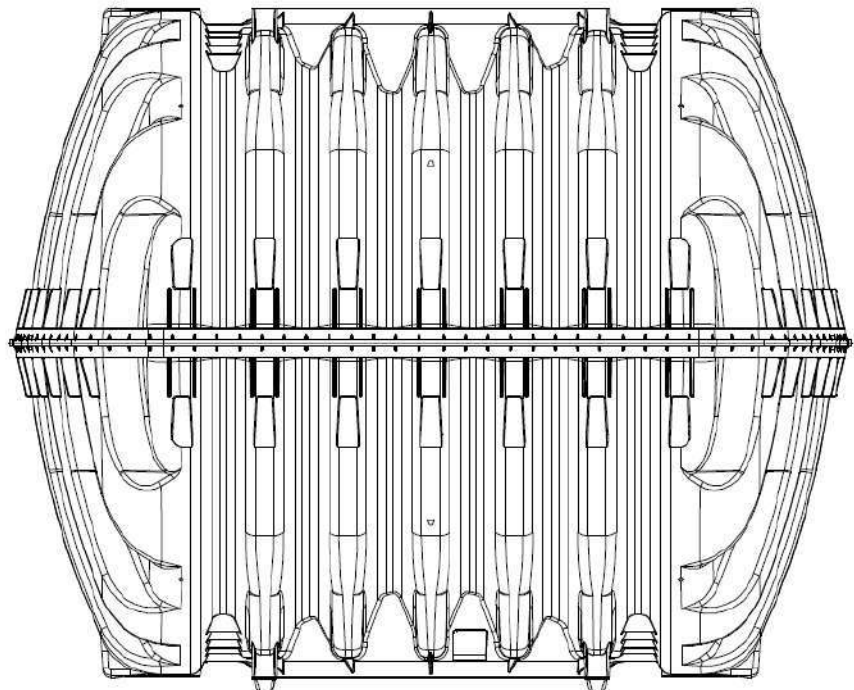

Installation and assembly

Excavations and manual tampering/compaction details

1. Natural earth
2. Telescopic shaft
3. Level compacted foundation – 20mm porous crushed rock (Type B) (see page 1)
4. Surrounding
5. Finished ground level
6. Carat underground tank
7. Concrete layer for vehicular traffic surfaces
8. (refer diagram 6.5)
9. Trench battering as per local regulations

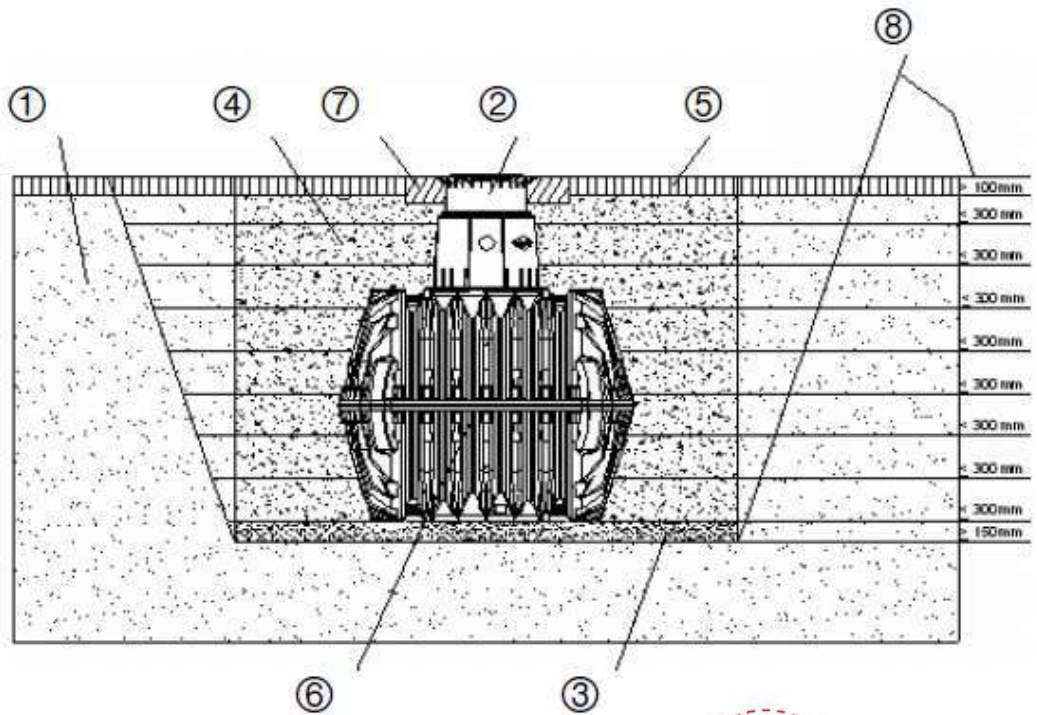

Note: Hole must be compacted in 300mm layers

Tank Assembly

1. Insert the profile seal 1 into the sealing 2 groove in the lower half of the tank shell 4. Refer diagram 5.1.1
2. Insert the plastic locating pins 3 into the holes provided around the lower half of the tank shell. Refer diagram 5.1.2
Lightly coat by hand the seal 1 with the liquid tube of liquid soap.
3. Position the upper half of the tank shell 5 onto the lower half 4 and install the quick connectors 6. To do this, every second quick connector is secured in a clock-wise direction using a hammer and a wooden block. The remaining quick connectors are then installed in a counter clock-wise direction. Refer diagram 5.1.3

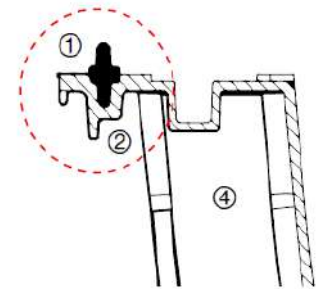

Diagram 5.1.1

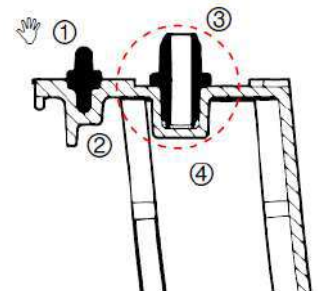

Diagram 5.1.2

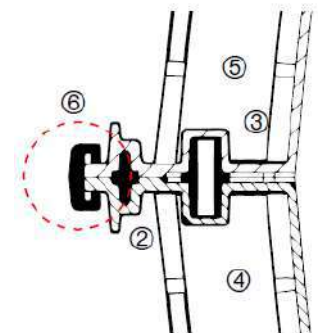

Diagram 5.1.3

Attention: When positioning the upper half tank shell on top of the lower half tank shell make sure under all circumstances that the seal does not slip out of the sealing groove.

Construction site pre-check

The following points should be Clarified before installation commences:

- The structural suitability of the ground (geotechnical report recommended)*
- Maximum groundwater levels which occur and drainage capability of the subsoil
- Types of load expected, for example: traffic loads
- Location of all underground services

*a geotechnical report conducted by civil testing engineers is strongly recommended to determine the physical characteristics of the subsoil before installation/excavation commences. For setback distance from neighbouring boundary and any buildings, please contact local council.

Trench excavation

Ensure sufficient space, (not less than 300mm) is available for working around the tanks during installation. Excavated soil must be kept well clear of the hole to prevent cave in.

The distance from solid constructions must comply with local regulations; refer to the current Building Code of Australia (BCA) – “angle of repose”). The trench embankment must be designed so that slippage or collapse of the embankment wall will not occur. As each state or territory Workplace, Health and Safety legislation differs in relation to trenching, reference should be made to your state or territory legislation with respect to trenching. A level layer of mechanically compacted Type B crushed rock (depth approx. 100mm – 150mm) is applied as the foundation of the excavation. The depth of the trench must be calculated so that the maximum earth coverage (see section 2 Depth of soil cover) above the tank is not exceeded. Installed plumbing pipes shall comply with AS3500.1:2003

Note: The iCON tank must not be concreted into place.

Groundwater and impermeable soil types

Consideration must be allowed for the drainage of ground water if it is anticipated that the tanks will be immersed deeper into the groundwater than shown in diagram 5.3.1 (shaded area). Refer to table 5.3.1 for recommended maximum immersion depths.

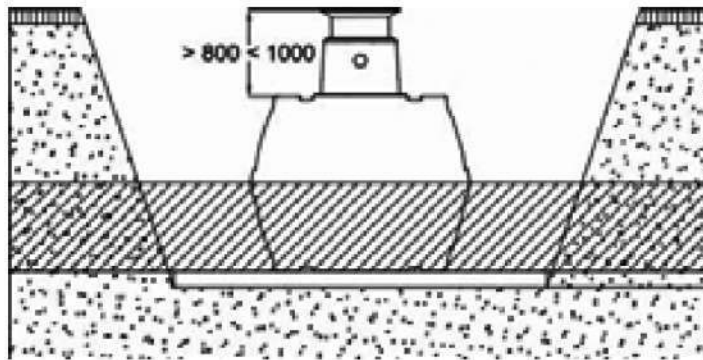

In the event that ground water is evident at the base of the hole, place a 225mm piece of PVC pipe in one corner of the excavation. Inside this PVC pipe insert a sump pump and drain the hole of ground water. Leave the pump to run until backfill is up to dome level.) Backfill in 300mm layers. Once backfilling is up to dome, remove pump and PVC pipe and fill hole and complete installation.

Table 5.3.1

Table 5.3.1				
Tank Size (L)	2700L	3750L	4800L	6500L
Immersion Depth (mm)	700mm	795mm	910mm	1050mm

Installation near to surfaces subject to heavy vehicle traffic

If the underground tanks are installed adjacent to surfaces which are used by vehicles heavier than passenger cars, the maximum distance D1 away from these surfaces is at least the depth D2 of the trench.

Note iCON tanks must not be installed below areas used by vehicles heavier than passenger cars.

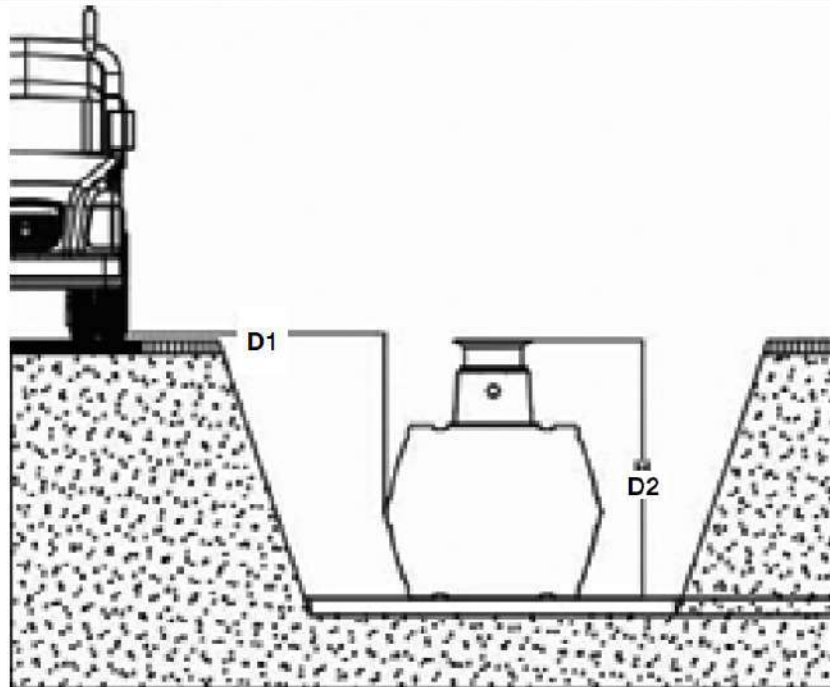

Diagram 5.3.2

Slope, embankment, etc.

On installation of the tank in the immediate vicinity (<5m) of a slope, a statically calculated (by an engineer) supporting wall must be erected to absorb the soil pressure. The wall must exceed the dimensions of the tank by at least 500mm in all directions; and must be located at least 1m away from the tank.

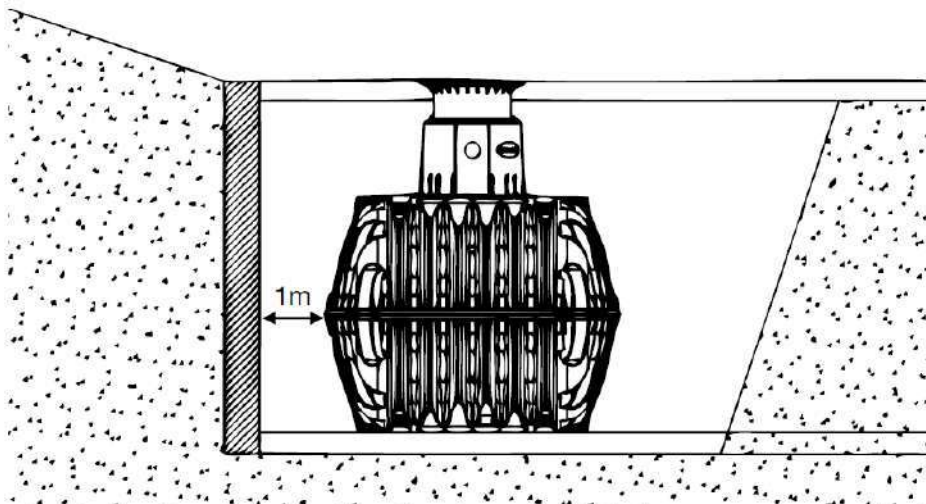

Diagram 5.3.3

Placement and filling of tank and trench excavation

The tank must be lowered impact free into the prepared trench excavation using suitable lifting equipment. As Workplace Health and Safety legislation differs in each state or territory reference should be made to your state or territory Workplace Health and Safety legislation with respect to lifting equipment.

1. To prevent deformities to the tank shell, the tank must be filled 1/3 with water before backfilling the surrounding trench.
2. The surrounding area of the excavation is filled in layers (maximum 30cm steps) of appropriate fill as per Page 1. The individual layers must be well tempered/compacted by hand held machine. Damage to the tank must be avoided during tampered/compacting of backfill.

NOTE:

- Place dome onto tank before adding water or backfilling.
- Under no circumstances can the trench be backfilled directly from the tip truck.
- Ensure all tank openings are sealed before backfilling.
- Only hand held mechanical compaction machines are to be used.

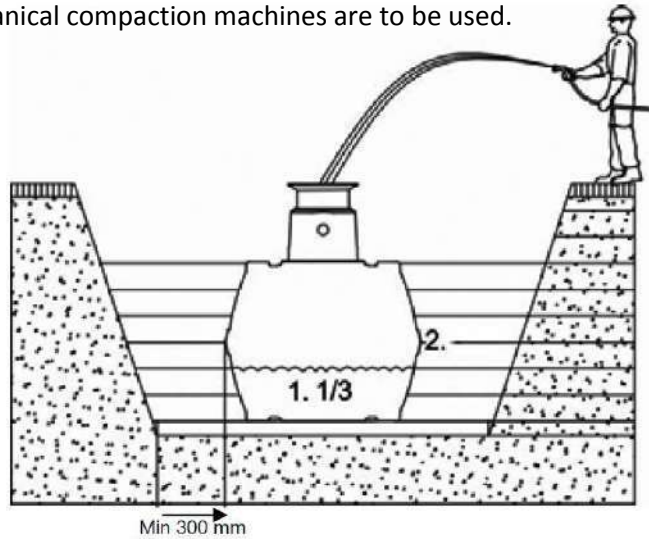

Diagram 5.4

Plumbing of feed and overflow pipes

All feed and overflow drain pipes must be laid on a grade of at least 1% in the direction of flow. Subsequent settling is possible and must be considered.

The tank and overflows connected to stormwater, it must be protected against reflux by using a suitable and accessible non-return valve and be in accordance with local regulations.

Suction, pressure and control lines

All suction lines, pressure and control lines must be installed through suitable 100mm pipe conduits.

The pipes need to be laid as straight as possible and with a grade of at least 1% in the direction of the tank.

If necessary, long radius (5 times diameter) moulded electrical conduit bends should be used.

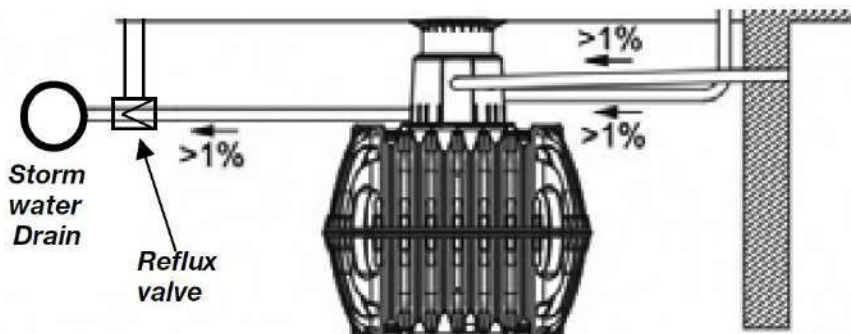

Diagram 5.5

Depth of drainage pipes to storm water and location from tank dome will vary according to filter selection, if applicable

Assembly of the tank dome and seal

Installation of the tank dome seal



1.



2.

B



3.

Assembling the tank dome and seals

Prior to assembly, the enclosed seal is inserted into the tank domes' groove B. The tank dome is then aligned with the piping connections and is pushed into the tank neck. It is essential to make sure that the upper seal A is correctly installed.

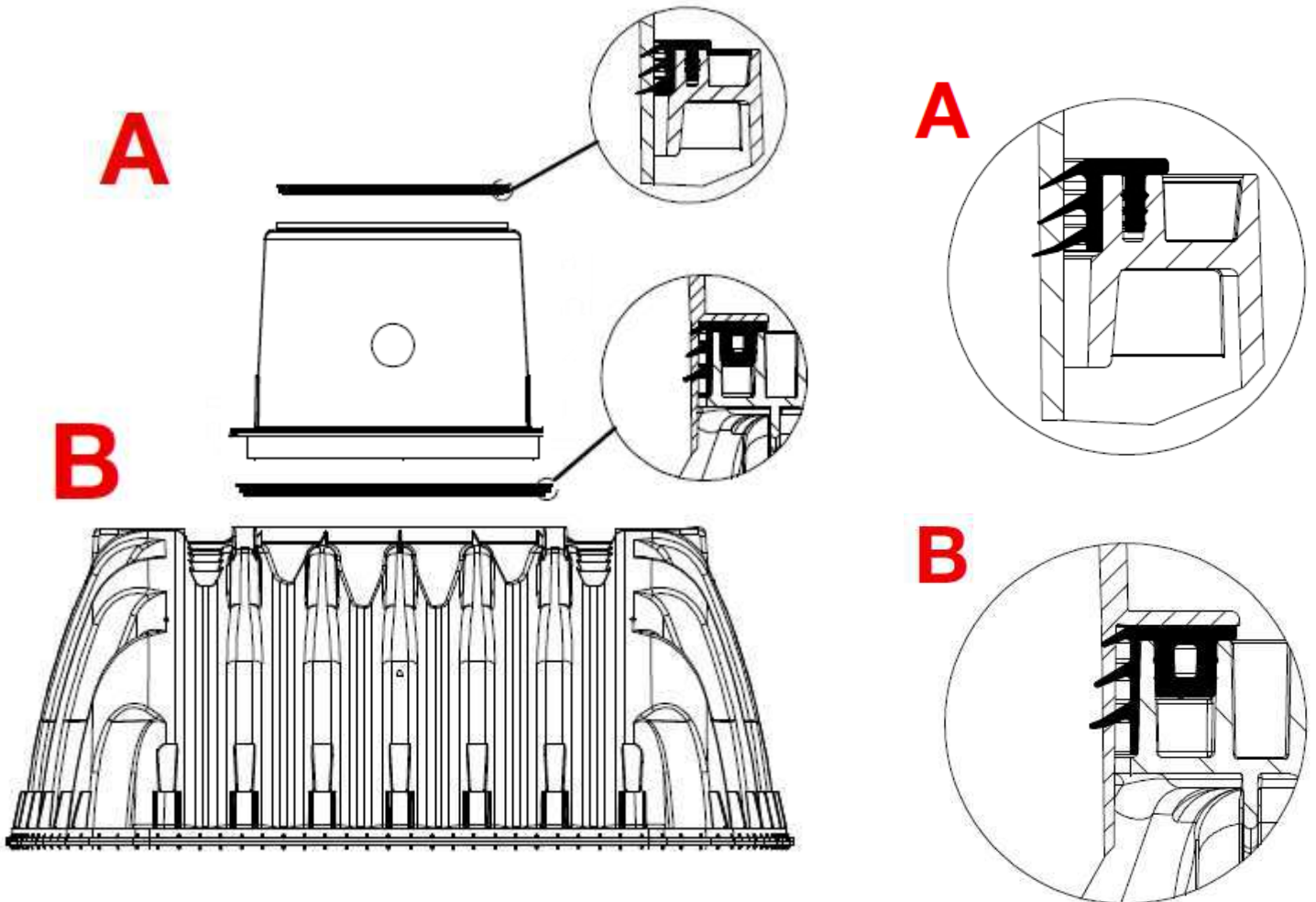

Assembly of the telescopic dome shaft & PE lid

For assembly purposes, the enclosed profile seal (A) is inserted into the tank dome sealing groove and is coated generously with 4eh liquid soap, supplied (do not use mineral oil-based lubricants, as these attack the seal). The telescope is then lubricated, inserted and aligned with the ground level. As legislation differs in each state or territory, reference should be made to Workplace Health and Safety legislation pertaining to confined spaces and working at heights.

The telescopic shaft pushes into the dome and is adjustable between 140mm and 340mm (standard shaft) and 140mm and 440mm (vehicle shaft). In the event that the shaft is too long it can be cut off to suit. The cut may require chamfering around the edge that fits into the rubber seal of the dome.

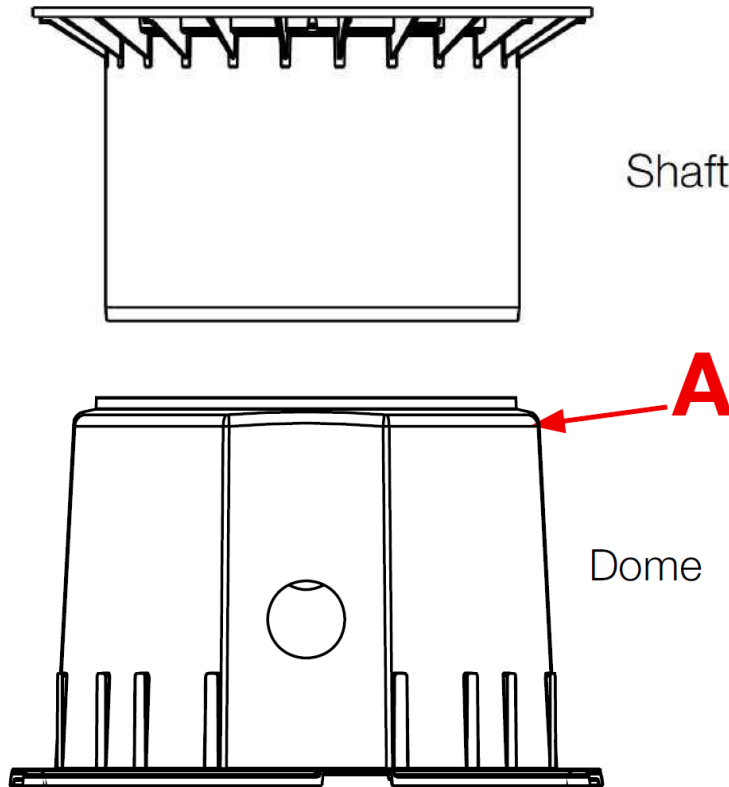

Diagram 6.3

Assembly of the telescopic tank shaft suitable for pedestrian traffic.

Important: To prevent loads from being transferred onto the tank, use appropriate fill as per page 1. 2 is manually filled in and evenly tampered/compacted, in layers around the shaft 1. Damage to the tank dome 3 and telescopic, must be avoided. The lid is then positioned, tightened and sealed to prevent unauthorised entry.

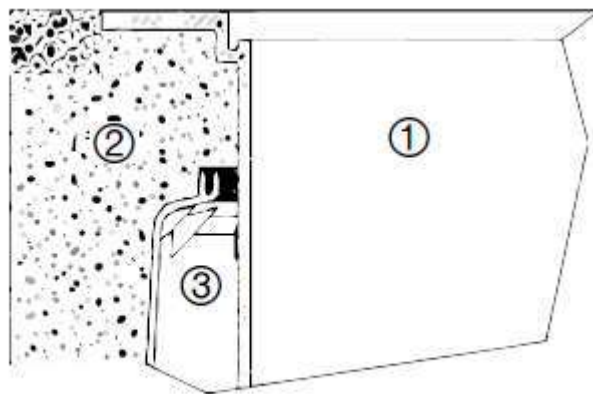

Diagram 6.4

Assembly of the telescopic dome shaft suitable for passenger vehicle traffic

If the tank installed in areas used by passenger cars, the collar area of the shaft 1 must be supported with concrete 4 (load rating = 250mPa). The layer of concrete to be installed must be at least 300mm wider in radius than the top of the shaft and not less than 200mm deep all around.

The minimum coverage above the shoulder of the tank must be 800mm (max. 1050 mm with shaft, coverage up to max. 1200mm possible with the optional extension riser).

Attention: Always use the cast iron cover option where installations are subject to passenger vehicle traffic. As cast iron lids weigh 50kg the property owner may decide to choose one of the external iCON Filters as an option. See Pages 17-22.

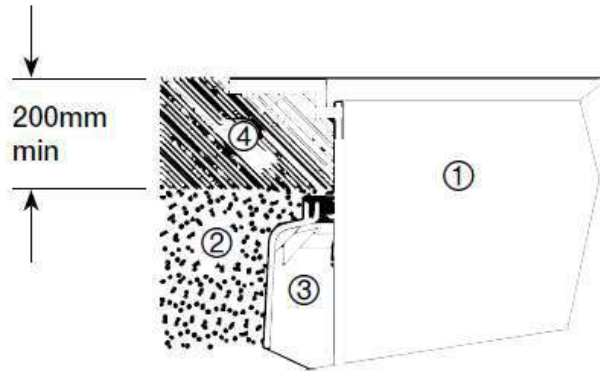

Diagram 6.5

For installations requiring Type D covers for heavy vehicles please contact your supplier for advice.

Assembling the optional extension risers

For iCON tanks buried deeper in the ground, optional extension risers are needed to extend the shaft to the surface. To assist the insertion of the adapter into the tank dome, liquid soap (supplied) is required. The profile seal is inserted into the highest groove on the inside of the riser and lubricated generously. Push the telescopic shaft into the riser and adjust it to the planned height of the surrounding surface.

One riser fitted equals a maximum earth-cover of 1200mm.

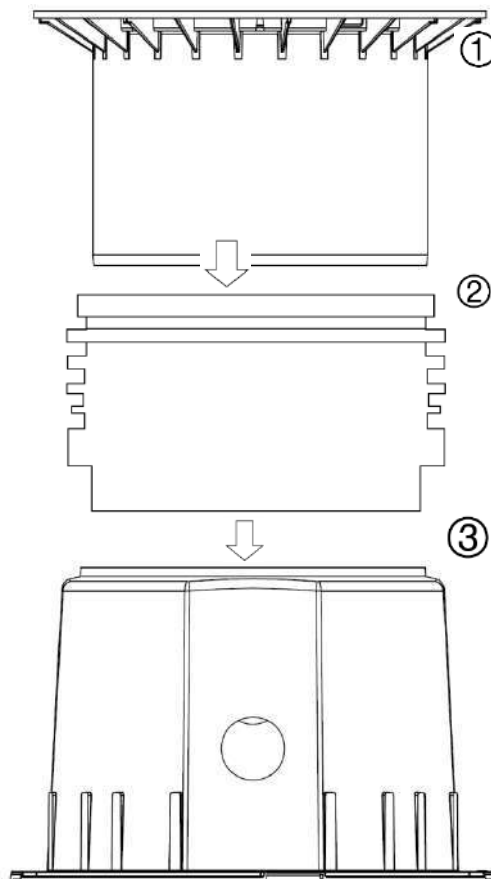

1. Telescopic shaft (can be adjusted up to 5° from horizontal, to suit undulating ground)

2. Extension Riser

3. Tank dome (can be rotated by 360°)
Maximum adjustment 300mm

Diagram 6.6

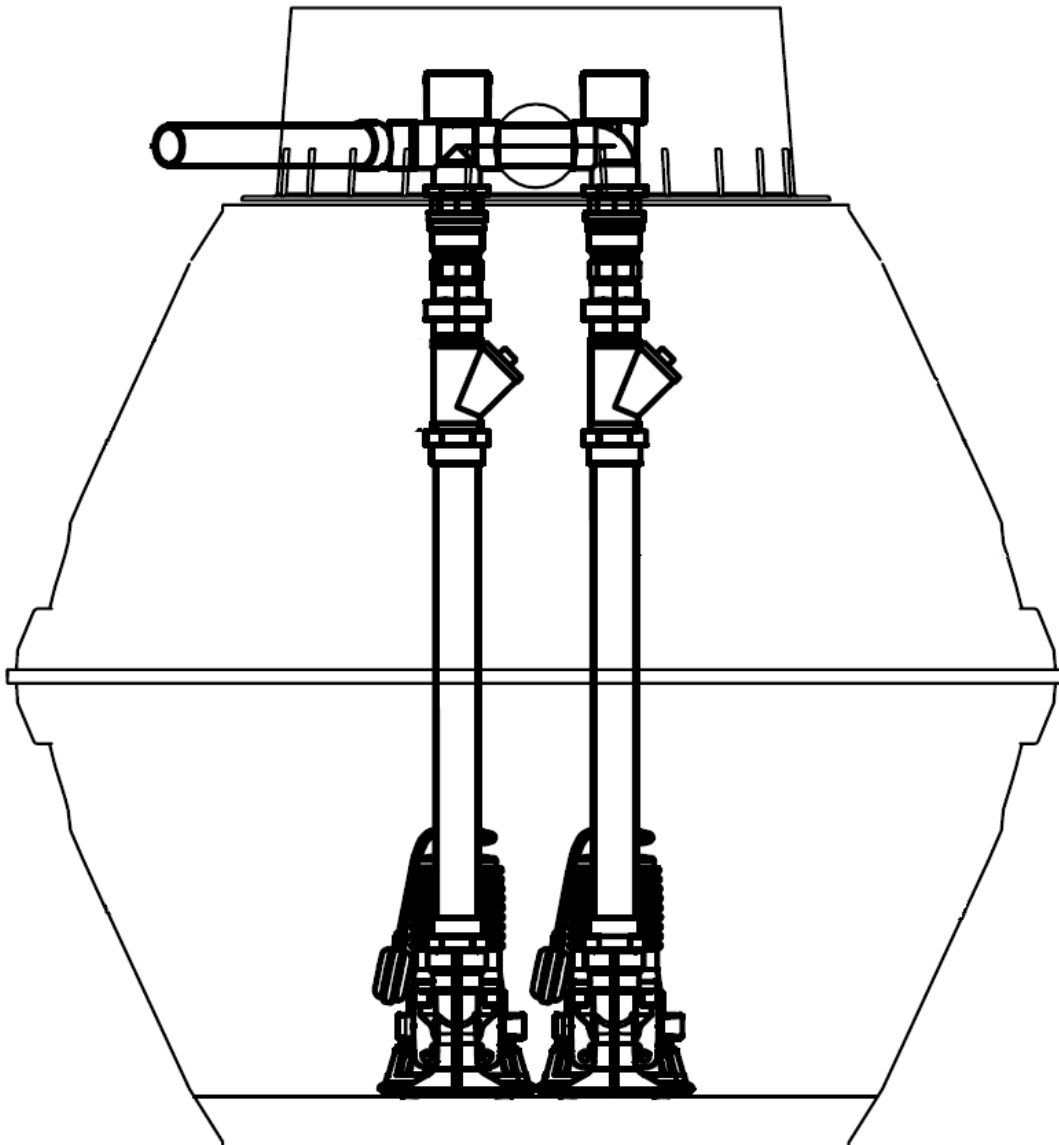
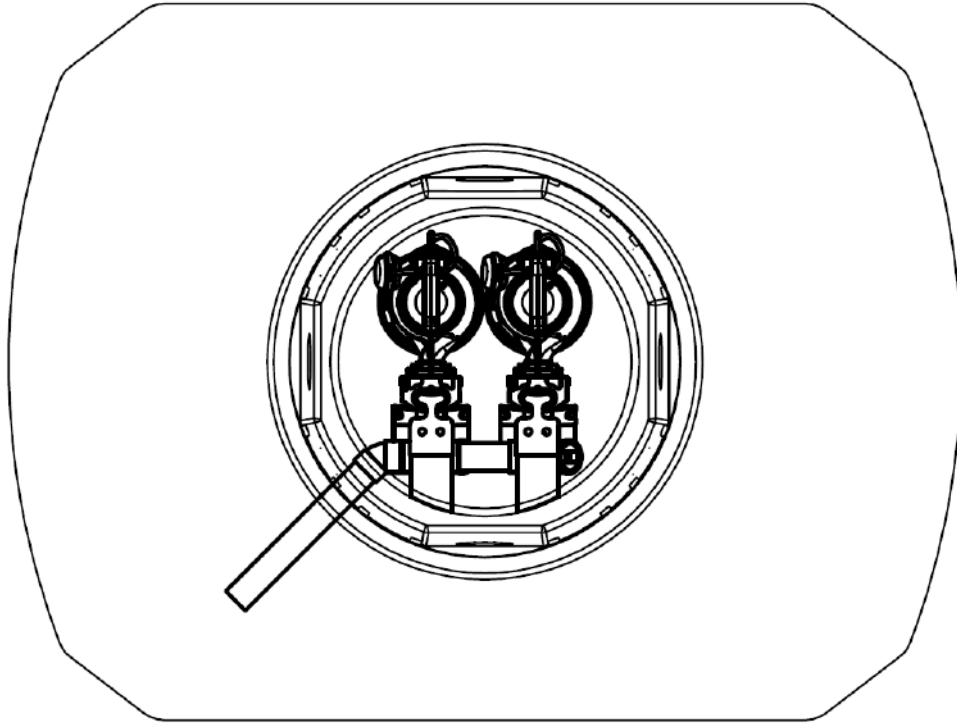

Correct use of iCON dome holes (maxi dome)

Note: Use only supplied liquid soaps as lubricant when inserting pipes.

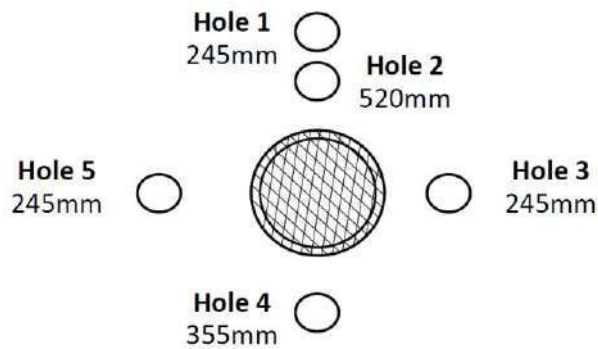
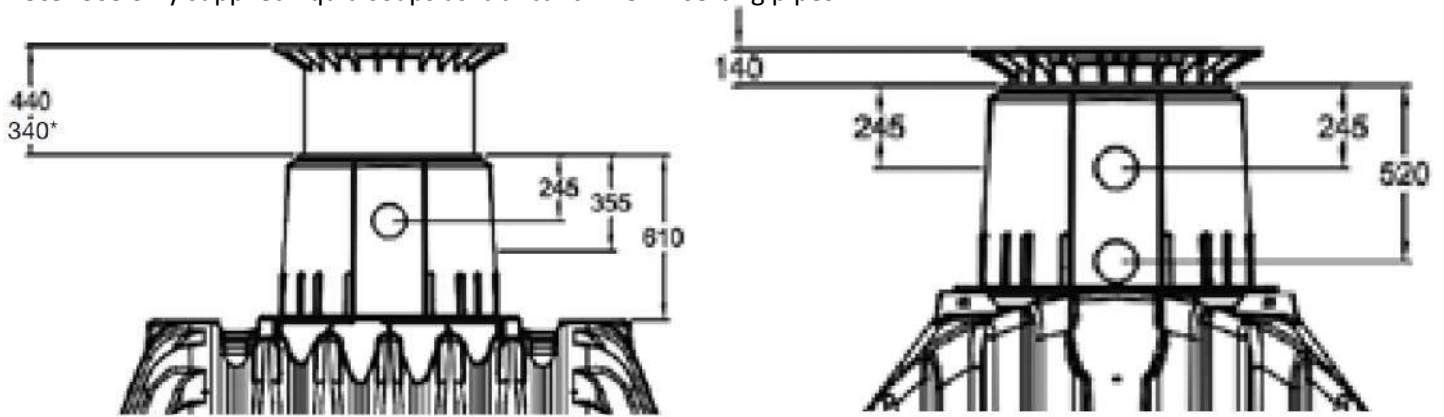

Inspection and servicing

The entire system must be inspected for leaks, at the completion of the work. Settling of soil might occur and consideration needs to be given to allow for such.

Depending on local conditions the system may need to be serviced at regular intervals, but not exceeding 5 years.

In this case, all parts of the system should be cleaned thoroughly and their function checked. Servicing should be carried out as follows:

- Isolate water and power connections
- Drain the tank
- Clean surfaces and internal parts with clean water
- Remove any dirt/debris from the tank
- Check that all internal parts are properly positioned and firmly seated.

In the event of work carried out inside the tank, as Workplace, Health and Safety legislation differs from each state and territory, reference must be made to Workplace Health and Safety legislation pertaining to confined spaces.

Note: Please refer to safety notes and General Safety Instructions at the front of this instruction manual.